

Prestige 630-C Series

ADSL USB Modem

User's Guide

Macintosh OS 9 and X

August 2003

ZyXEL
Unleash Networking Power

Copyright

Copyright ©2003 by ZyXEL Communications Corporation

The contents of this publication may not be reproduced in any part or as a whole, transcribed, stored in a retrieval system, translated into any language, or transmitted in any form or by any means, electronic, mechanical, magnetic, optical, chemical, photocopying, manual, or otherwise, without the prior written permission of ZyXEL Communications Corporation.

Published by ZyXEL Communications Corporation. All rights reserved.

Disclaimer

ZyXEL does not assume any liability arising out of the application or use of any products, or software described herein. Neither does it convey any license under its patent rights nor the patents' rights of others. ZyXEL further reserves the right to make changes in any products described herein without notice. This publication is subject to change without notice.

Trademarks

Trademarks mentioned in this publication are used for identification purposes only and may be properties of their respective owners.

ZyXEL Limited Warranty

ZyXEL warrants to the original end user (purchaser) that this product is free from any defects in materials or workmanship for a period of up to two (2) years from the date of purchase. During the warranty period and upon proof of purchase, should the product have indications of failure due to faulty workmanship and/or materials, ZyXEL will, at its discretion, repair or replace the defective products or components without charge for either parts or labor and to whatever extent it shall deem necessary to restore the product or components to proper operating condition. Any replacement will consist of a new or re-manufactured functionally equivalent product of equal value, and will be solely at the discretion of ZyXEL. This warranty shall not apply if the product is modified, misused, tampered with, damaged by an act of God, or subjected to abnormal working conditions.

NOTE

Repair or replacement, as provided under this warranty, is the exclusive remedy of the purchaser. This warranty is in lieu of all other warranties, express or implied, including any implied warranty of merchantability or fitness for a particular use or purpose. ZyXEL shall in no event be held liable for indirect or consequential damages of any kind of character to the purchaser.

To obtain the services of this warranty, contact ZyXEL's Service Center for your Return Material Authorization number (RMA). Products must be returned Postage Prepaid. It is recommended that the unit be insured when shipped. Any returned products without proof of purchase or those with an out-dated warranty will be repaired or replaced (at the discretion of ZyXEL) and the customer will be billed for parts and labor. All repaired or replaced products will be shipped by ZyXEL to the corresponding return address, Postage Paid. This warranty gives you specific legal rights, and you may also have other rights that vary from country to country.



Online Registration

Register online at www.zyxel.com for free future product updates and information.

Information for Canadian Users

The Industry Canada label identifies certified equipment. This certification means that the equipment meets certain telecommunications network protective operation and safety requirements. The Industry Canada does not guarantee that the equipment will operate to a user's satisfaction.

Before installing this equipment, users should ensure that it is permissible to be connected to the facilities of the local telecommunications company. The equipment must also be installed using an acceptable method of connection. In some cases, the company's inside wiring associated with a single line individual service may be extended by means of a certified connector assembly. The customer should be aware that compliance with the above conditions may not prevent degradation of service in some situations.

Repairs to certified equipment should be made by an authorized Canadian maintenance facility designated by the supplier. Any repairs or alterations made by the user to this equipment, or equipment malfunctions, may give the telecommunications company cause to request the user to disconnect the equipment.

For their own protection, users should ensure that the electrical ground connections of the power utility, telephone lines, and internal metallic water pipe system, if present, are connected together. This precaution may be particularly important in rural areas.

Caution

Users should not attempt to make such connections themselves, but should contact the appropriate electrical inspection authority, or electrician, as appropriate.

Note

This digital apparatus does not exceed the Class A limits for radio noise emissions from digital apparatus set out in the radio interference regulations of Industry.

Federal Communications Commission (FCC) Interference Statement

This device complies with Part 15 of FCC rules. Operation is subject to the following two conditions:

This device may not cause harmful interference.

This device must accept any interference received, including interference that may cause undesired operations.

This equipment has been tested and found to comply with the limits for a CLASS B digital device pursuant to Part 15 of the FCC Rules. These limits are designed to provide reasonable protection against harmful interference in a commercial environment. This equipment generates, uses, and can radiate radio frequency energy, and if not installed and used in accordance with the instructions, may cause harmful interference to radio communications.

If this equipment does cause harmful interference to radio/television reception, which can be determined by turning the equipment off and on, the user is encouraged to try to correct the interference by one or more of the following measures:

Reorient or relocate the receiving antenna.

Increase the separation between the equipment and the receiver.

Connect the equipment into an outlet on a circuit different from that to which the receiver is connected.

Consult the dealer or an experienced radio/TV technician for help.

Notice 1

Changes or modifications not expressly approved by the party responsible for compliance could void the user's authority to operate the equipment.

Certifications

Refer to the product page at www.zyxel.com.

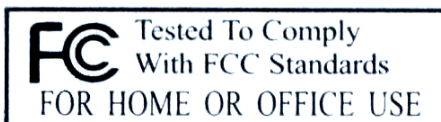

Customer Support

When contacting your Customer Support Representative, please have the following information ready:

- ◆ Product model and serial number.
- ◆ Warranty Information.
- ◆ Date you received your Product.
- ◆ Brief description of the problem and the steps you took to solve it.

METHOD	E-MAIL SUPPORT/SALES	TELEPHONE/FAX	WEB SITE/ FTP SITE	REGULAR MAIL
LOCATION				
WORLDWIDE	support@zyxel.com.tw sales@zyxel.com.tw	+886-3-578-3942 +886-3-578-2439	www.zyxel.com www.europe.zyxel.com ftp.europe.zyxel.com	ZyXEL Communications Corp., 6 Innovation Road II, Science- Based Industrial Park, Hsinchu 300, Taiwan
NORTH AMERICA	support@zyxel.com sales@zyxel.com	1-800-255-4101	www.us.zyxel.com ftp.zyxel.com	
SCANDINAVIA	support@zyxel.dk sales@zyxel.dk	+45-3955-0700 +45-3955-0707	www.zyxel.dk ftp.zyxel.dk	ZyXEL Communications A/S, Columbusvej 5, 2860 Soeborg, Denmark
FINLAND	sales@zyxel.fi	+359-9-4780-8400 +359-9-4780-8448	http://www.zyxel.fi/	ZyXEL Communications Oy, Malminkaari 10 00700 Helsinki, Finland
GERMANY	support@zyxel.de sales@zyxel.de	+49-2405-6909-0 +49-2405-6909-99	www.zyxel.de	ZyXEL Deutschland GmbH. Adenauerstr. 20/A2 D-52146 Wuerselen, Germany

Table of Contents

<i>Copyright</i>	<i>ii</i>
<i>ZyXEL Limited Warranty</i>	<i>iii</i>
<i>Information for Canadian Users</i>	<i>iv</i>
<i>Federal Communications Commission (FCC) Interference Statement</i>	<i>v</i>
<i>Customer Support</i>	<i>vi</i>
<i>List of Diagrams</i>	<i>x</i>
<i>List of Tables</i>	<i>x</i>
<i>Preface</i>	<i>xi</i>
<i>About ADSL</i>	<i>xiii</i>
<i>About USB</i>	<i>xiv</i>
Chapter 1 Getting to Know Your Prestige	1-1
1.1 <i>Introducing the Prestige 630-C Series ADSL USB Modem</i>	<i>1-1</i>
1.2 <i>Features</i>	<i>1-1</i>
Chapter 2 Hardware Installation	2-1
2.1 <i>Hardware Overview</i>	<i>2-1</i>
Chapter 3 Installing Your Modem	3-1
3.1 <i>Operating Systems</i>	<i>3-1</i>
3.2 <i>Internet Account Information</i>	<i>3-1</i>
3.3 <i>Installing the Web Configurator Driver</i>	<i>3-2</i>
Chapter 4 Introducing the Web Configurator	4-1
4.1 <i>Making a DSL Connection</i>	<i>4-1</i>
Chapter 5 Status Information	5-1
5.1 <i>Prestige Status Information Overview</i>	<i>5-1</i>
5.2 <i>ADSL Status Information</i>	<i>5-1</i>
5.3 <i>Viewing LAN Status</i>	<i>5-3</i>
5.4 <i>Viewing PPP Interface Status</i>	<i>5-4</i>
Chapter 6 Basic Configuration	6-1
6.1 <i>Configuration Overview</i>	<i>6-1</i>
6.2 <i>Configuring WAN</i>	<i>6-1</i>
6.3 <i>Configuring LAN</i>	<i>6-5</i>
6.4 <i>Configuring DNS</i>	<i>6-7</i>
6.5 <i>Saving New Settings</i>	<i>6-8</i>
Chapter 7 Administrative Privileges	7-1
7.1 <i>Administration Privileges Overview</i>	<i>7-1</i>
7.2 <i>WAN Status</i>	<i>7-1</i>
7.3 <i>ATM Status</i>	<i>7-2</i>
7.4 <i>TCP Status</i>	<i>7-3</i>
7.5 <i>ADSL Configuration</i>	<i>7-5</i>
7.6 <i>Admin Password Configuration</i>	<i>7-6</i>
7.7 <i>User Password Configuration</i>	<i>7-7</i>

7.8	<i>Miscellaneous Configuration</i>	7-8
7.9	<i>Restoring Factory Defaults</i>	7-9
7.10	<i>Performing a Diagnostic Test</i>	7-10
7.11	<i>System Log</i>	7-11
7.12	<i>Making a DSL Connection with PPPoE</i>	7-12
7.13	<i>Uninstalling the Hardware and Driver</i>	7-14
Chapter 8	Troubleshooting	8-1
Appendix A	Setting up Your Computer's IP Address	C
Appendix B	Virtual Circuit Topology	G
	<i>Index</i>	<i>I</i>

List of Figures

Figure 2-1 Back Panel Connections	2-1
Figure 2-2 USB Cable Connectors	2-1
Figure 2-3 Splitter	2-2
Figure 2-4 Microfilter.....	2-2
Figure 2-5 Front Panel LEDs	2-1
Figure 3-1 About This Mac	3-1
Figure 3-2 Mac OS 9 Installation File.....	3-3
Figure 3-3 Installation Authorization	3-4
Figure 3-4 Select a Destination Drive	3-5
Figure 4-1 Open System Preferences	4-1
Figure 4-2 System Preferences.....	4-1
Figure 4-3 New Port Detected.....	4-2
Figure 4-4 Network: TCP/IP Tab	4-3
Figure 4-5 Home Page.....	4-4
Figure 5-1 ADSL Status.....	5-2
Figure 5-2 PPP Status.....	5-5
Figure 6-1 WAN Configuration	6-2
Figure 6-2 LAN Configuration.....	6-6
Figure 6-3 DNS Configuration.....	6-7
Figure 6-4 Save Settings.....	6-8
Figure 7-1 WAN Status.....	7-1
Figure 7-2 ATM Status.....	7-3
Figure 7-3 TCP Status	7-4
Figure 7-4 ADSL Configuration	7-6
Figure 7-5 Admin Password Configuration.....	7-7
Figure 7-6 User Password Configuration	7-7
Figure 7-7 Miscellaneous Configuration.....	7-8
Figure 7-8 Restore Factory Defaults	7-9
Figure 7-9 Diagnostic Test.....	7-10
Figure 7-10 System Log.....	7-12
Figure 7-11 Network: PPPoE Tab.....	7-13
Figure 7-12 PPPoE Icon Connect.....	7-13

List of Diagrams

Diagram 1 Virtual Circuit Topology.....	E
---	---

List of Tables

Table 2-1 LED Descriptions	2-1
Table 5-1 ADSL Status	5-2
Table 5-2 LAN Status	5-4
Table 5-3 PPP Status	5-5
Table 6-1 WAN Configuration	6-3
Table 6-2 WAN Configuration Options.....	6-4
Table 6-3 LAN Configuration.....	6-6
Table 6-4 DNS Configuration.....	6-8
Table 7-1 WAN Status	7-1
Table 7-2 ATM Status.....	7-3
Table 7-3 TCP Status	7-5
Table 7-4 ADSL Configuration	7-6
Table 7-5 Admin Password Configuration.....	7-7
Table 7-6 User Password Configuration	7-8
Table 7-7 Miscellaneous Configuration.....	7-9
Table 7-8 Diagnostic Test	7-10
Table 7-9 System Log	7-12
Table 8-1 Troubleshooting.....	8-1

Preface

Congratulations on your purchase from the Prestige 630-C ADSL USB Modem Series.

Your USB-powered Prestige supports an upstream data rate of 800 Kbps and is compatible with all G.DMT compliant Central Office (CO) Digital Subscriber Line Access Multiplexer (DSLAM) equipment.

Your Prestige is easy to install and configure. All functions are configurable via the ZyXEL configuration wizard and web configurator.

Related Documentation

➤ Support Disk

Refer to the included CD for support documents.

➤ Quick Start Guide

The Quick Start Guide is designed to help you get up and running right away. It contains general connection and initial configuration instructions.

➤ Certifications

Refer to the product page at www.zyxel.com for information on product certifications.

➤ ZyXEL Web Site

The ZyXEL download library at www.zyxel.com contains additional support documentation as well as an online glossary of networking terms.

Help us help you. E-mail all User Guide-related comments, questions or suggestions for improvement to techwriters@zyxel.com.tw or send regular mail to The Technical Writing Team, ZyXEL Communications Corp., 6 Innovation Road II, Science-Based Industrial Park, Hsinchu, 300, Taiwan. Thank you.

About This User's Guide

This User's Guide provides instructions for using the Prestige 630-C1 ADSL USB modem with Macintosh computers using **Mac OS versions 9.1, 9.2.1, 9.2.2, 10.1.5, 10.2, 10.2.1**. All figures shown are in Mac OS X format.

All graphics in this *User's Guide* show the Mac OS X interface. Familiarize yourself with the *Syntax Conventions* listed next for better and faster understanding.

Syntax Conventions

- Mouse action sequences are denoted using a comma. For example, “click the Apple icon, **Control Panels** and then **Modem**” means first click the Apple icon, then click or move your mouse pointer over **Control Panels** and then click or (double-click) **Modem**.
- "Select" or "Choose" means for you to use one of the predefined choices.
- Button and field labels, links and screen names are in **Bold Times New Roman** font.
- Predefined choices are in **Bold Arial** font.
- The “ZyXEL Prestige 630-C Series ADSL USB Modem” is also referred to as the “modem” the “Prestige” in this manual.

About ADSL

ADSL Overview

Asynchronous Digital Subscriber Line (ADSL) technology provides high-speed data access across regular telephone or ISDN lines by making use of previously unused high-frequency bandwidth. ADSL is asymmetric in the sense that it provides a higher downstream data rate transfer (up to 8Mbps), than in the upstream transfer (up to 832 Kbps). Asymmetric operation is ideal for typical home and small office use where files and information are downloaded more frequently than uploaded.

Advantages of ADSL

- 1.** ADSL provides a private (unlike cable telephone and modem services where the line is shared), dedicated and secure channel of communications between you and your service provider.
- 2.** Because your line is dedicated (not shared), transmission speeds are not affected by other users. With cable modems, transmission speeds drop significantly as more users go on-line because the line is shared.
- 3.** ADSL is "always on" (connected). This means that there is no time wasted dialing up the service several times a day and waiting to be connected; ADSL is on standby, ready for use whenever you need it.

About USB

USB

USB (Universal Serial Bus) is a data communications standard that allows your computer to recognize (auto-detect) new devices. No technical expertise is required to install your device. You simply plug your USB cable in and follow a limited set of easy-to-understand, automatically generated instructions. Set-up and operation has never been easier.

Advantages of USB

1. There is no need for numerous different types of ports and connectors on your computer. Modems, printers, joysticks, keyboards, mice, audio devices, CD-ROMs, digital cameras and other devices can all be connected through USB.
2. With USB, installing adapter cards, changing dip switches and configuring IRQs (Interrupt Requests) does not require opening your computer.
3. USB has data transfer rates of up to 12 Mbps.
4. Multiple devices can be daisy-chained to a single port without restarting your computer.
5. USB can power some devices - eliminating the need for batteries or power adapters.

Part I

The Web Configurator

This part covers configuring your Prestige using the Web Configurator.

Chapter 1

Getting to Know Your Prestige

This chapter covers the key features and main applications of your modem.

1.1 Introducing the Prestige 630-C Series ADSL USB Modem

The Prestige 630-C Series combines the super-fast speed of state-of-the-art ADSL (Asynchronous Digital Subscriber Line) technology with the ease of setup and operation facilitated by a USB (Universal Serial Bus) interface.

The ZyXEL configuration wizard provides an easy-to-use interface to configure your Prestige. You can also configure the modem through the embedded web configurator, which is totally independent of your operating system platform.

1.2 Features

This section describes the router's key features.

- Compliant with Universal Serial Bus Specification Revision 1.1
- USB bus-powered; an external power supply is not required
- Compatible with all G.DMT compliant Central Office (CO) Digital Subscriber Line Access Multiplexer (DSLAM) equipment
- Software upgradeable
- Includes a user interface screen for checking the status of the connection
- An RJ-11/RJ-45 port for ADSL connection
- Support for DSL downstream data rates of up to 8 Mbps.
- Support for DSL upstream data rates of up to 1 Mbps.

Chapter 2

Hardware Installation

This chapter introduces the ports and LED indicators.

2.1 Hardware Overview

Have your system operating disk handy during the installation, in case a specific file can not be found on your computer.

The back panel has two interfaces: a USB and an ADSL port as shown in the following figure.



Figure 2-1 Back Panel Connections

2.1.1 USB Connectors

See the following figure for an explanation of USB connectors.

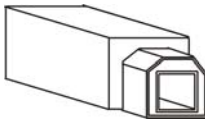

This cable end will plug into your modem's USB port.

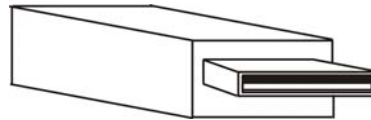

This cable end will plug into your computer's USB port.

Figure 2-2 USB Cable Connectors

2.1.2 Splitter and Microfilter

Use a splitter (optional) in order to plug a phone into the same ISDN or telephone line. See the following figure.

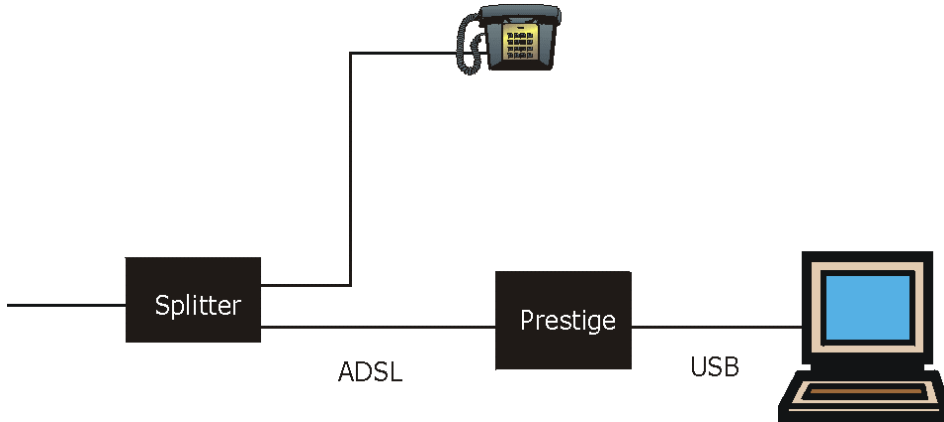

Figure 2-3 Splitter

You may opt to buy a telephone microfilter to install between the wall jack and your telephone(s). A microfilter acts as a low pass filter that screens out possible interference. See the following figure.

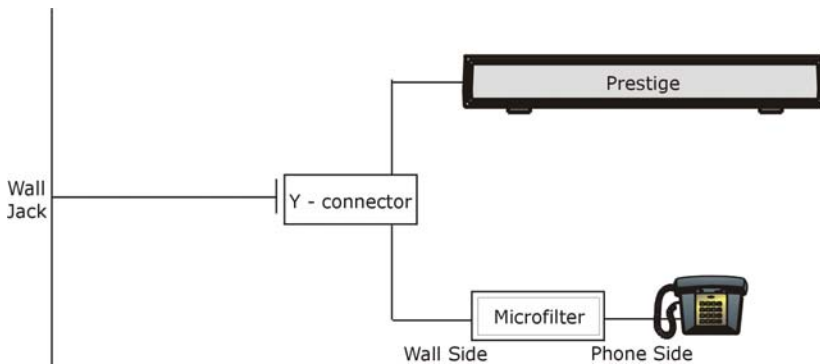

Figure 2-4 Microfilter

2.1.3 Front Panel LEDs

The LEDs on the front panel of your modem indicate operational status. The table under the following figure describes the LED functions.



Figure 2-5 Front Panel LEDs

The following table describes the functions of the LEDs.

Table 2-1 LED Descriptions

LED	FUNCTION	DESCRIPTION
USB	USB Interface and Modem Power Connection	<p>This LED is off when the modem's USB port is not connected or not receiving power.</p> <p>The LED is on when the USB is connected and receiving power.</p> <p>This LED blinks during data transfer or whenever the DSL link is up.</p>
DSL	DSL Interface	<p>This LED is off when there is no DSL connection.</p> <p>This LED is on when the ADSL link is up.</p> <p>This LED blinks when the ADSL link is connecting and the driver software is installed.</p>

Chapter 3

Installing Your Modem

This chapter shows you how to install your modem and USB driver and introduces the ports and LED indicators.

3.1 Operating Systems

The modem drivers are compatible with the Macintosh operating system versions 9 and X.

Click the Apple icon and then **About This Mac** in order to see which OS version is on your Macintosh.

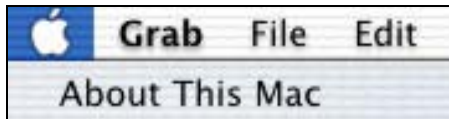

Figure 3-1 About This Mac

The screens on your computer may differ slightly from the screens shown here depending on the version of your operating system.

3.2 Internet Account Information

You should have an Internet account already set up and been given most of the following information.

REQUIRED INFORMATION:	FILL IN THE BLANKS
RFC CLIP, Bridged IP over ATM (RFC1483), PPPoA or PPPoE.	
RFC Mode (with Classical and Bridged IP over ATM only) Bridged or Routed.	
VPI: The Virtual Path Identifier number identifies a bundle of virtual channels.	
VCI: The Virtual Channel Identifier number identifies a logical connection between end stations.	

REQUIRED INFORMATION:	FILL IN THE BLANKS
Framing Type: LLC or VCMUX.	
Modulation: Your ISP will tell you which type of ADSL modulation it uses. The default is Automatic . Wiring Selection: This is the type of wire being used for the connection: Line Tip/Ring (default), Line A/A1 , or Automatic .	
User Name / Password: Lets your ISP know which account you are logging into and protects your account from unauthorized users.	
Vendor Name: The name of your vendor is also known as the ADSL Head End.	
ADSL Head End Env: Your ISP will provide you with this information: Non-Specific or No Line Driver (BNA)	

Your modem supports **RFC 1483**, **PPPoA** (Point to Point Protocol over ATM) and **PPPoE** (Point to Point Protocol over Ethernet) drivers. These refer to the underlying data transport protocols. The RFC 1483 driver works as an always-on account. The PPPoA and PPPoE drivers function as dial-up accounts.

When using the RFC 1483 driver, select the mode that your ISP uses, either **Bridged IP** or **Routed IP**.

The encapsulation type is also called multiplexing. Your modem supports both **LLC** and **VC/MUX**.

See the appendix for more information about VPI and VCI.

3.3 Installing the Web Configurator Driver

The following two sections describe how to install your and modem for both Mac OS 9 and X.

3.3.1 Mac OS 9 Installation

- Step 1.** Close all Windows programs and applications.
- Step 2.** Insert the included CD into the CD-ROM drive. An icon for the CD appears.
- Step 3.** Double-click the CD's icon.
- Step 4.** Copy the driver **OS9 Package.sit** to a directory on your Mac and double-click it.
- Step 5.** A folder named "install USB ADSL" will be created. Open this folder and double-click the **install** icon as shown next.

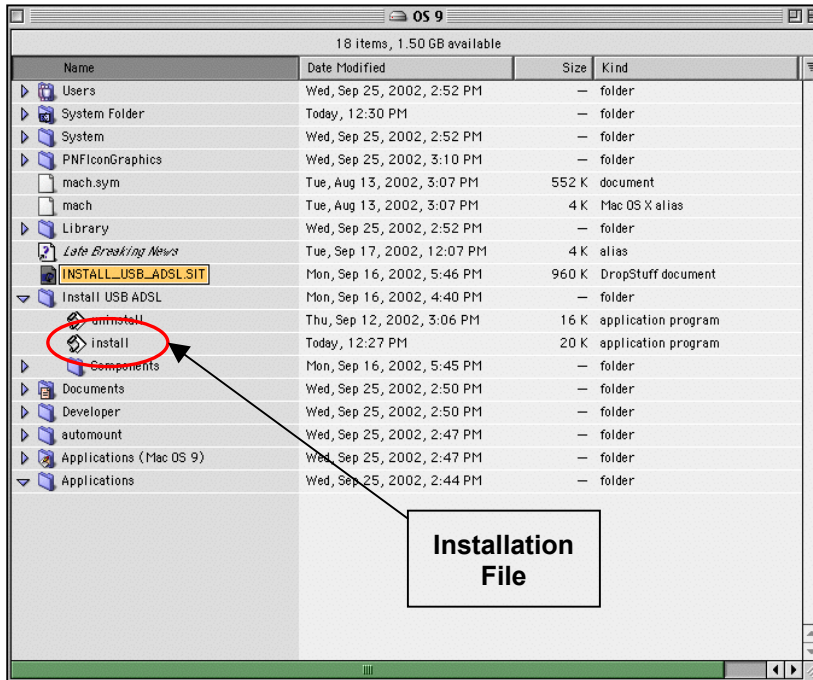

Figure 3-2 Mac OS 9 Installation File

Step 6. After installation is complete, restart your computer when prompted to do so.

3.3.2 Mac OS X Installation

Step 1. Close all Windows programs and applications.

Step 2. Insert the included CD into the CD-ROM drive. An icon for the CD appears.

Step 3. Double-click the CD's icon.

Step 4. Copy the driver **CMX.1.O.X.sit** to the desktop and extract this .sit file.

Step 5. The file **install USB ADSL.pkg** and **uninstall** script will be created.

Step 6. Double-click **install USB ADSL.pkg** to install the driver.

- Step 7.** An installation window will appear and prompt you for authorization. It is highly recommended that you click the **Click the lock to make changes** button to input an administrator password. This password will be required every time changes need to be made to the Prestige. Click **OK**.



Figure 3-3 Installation Authorization

- Step 8.** After you log in, you will see an Introduction screen. Click **Continue**. You will then see the **Select a Destination** window, select a destination (this must be on an actual physical hard drive on the Macintosh, not a virtual drive) and click **Continue**.

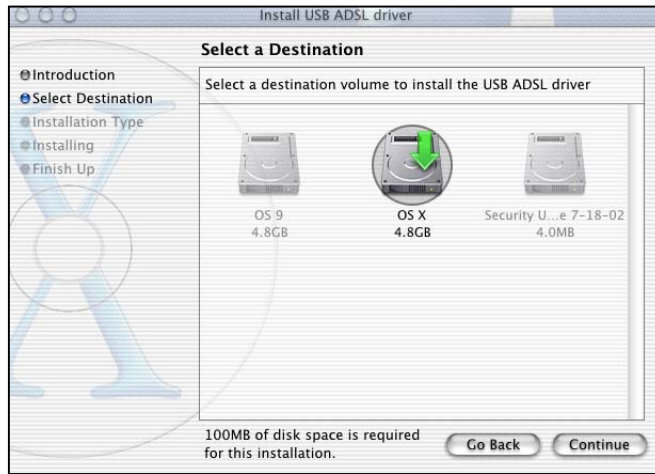

Figure 3-4 Select a Destination Drive

- Step 9.** Click **Install** and then **Continue Installation** in the **Installation Type** window. The driver will automatically install and your MAC will restart.

Chapter 4

Introducing the Web Configurator

This chapter describes how to configure your Prestige with the embedded web configurator.

4.1 Making a DSL Connection

Use the following steps to configure your Macintosh when using the installed driver.

Step 1. Click the Apple icon and **System Preferences**.

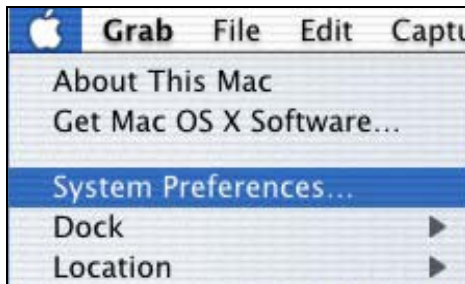

Figure 4-1 Open System Preferences

Step 2. Click **Network**.

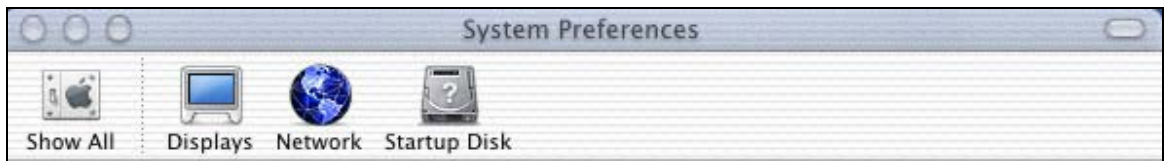

Figure 4-2 System Preferences

Step 3. A **New Port Detected** screen opens when the computer detects that the ADSL link is up. Click **OK**.



Figure 4-3 New Port Detected

- Step 4.** In the **Network** screen, select **Ethernet Adaptor (en x)** in the **Show** field. In the **TCP/IP** tab, select **Using DHCP** in the **Configure** field if you are using the bridged IP mode or **Manually** if you are using the routed IP mode. Click **Apply Now**.

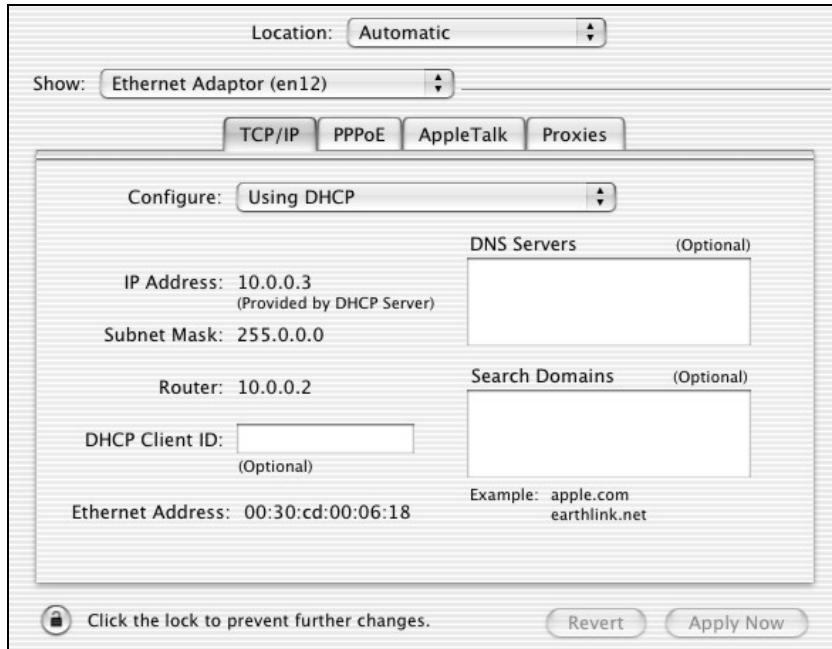

Figure 4-4 Network: TCP/IP Tab

- Step 5.** Open your web browser and enter “10.0.0.2” as the address. The following login prompt will appear.



- Step 6.** For administrative access, type "admin" as the **User ID** and “epicrouter” as the **Password**. For user access, type “user” as the **User ID** and “password” as the **Password**. You may change these at a later time. Click **OK**.

You should now see the **Home Page** screen. From this screen, you can also view current WAN and LAN settings, as well as firmware and software versions.

ZyXEL
Unleash Networking I

Home Page

Firmware Version: **ETHADSL_USB_043002_REL17_E**
 Showtime Firmware Version: **3.18**
 Customer Software Version:

WAN

IP Address	Subnet Mask	MAC Address

LAN

IP Address	Subnet Mask	MAC Address
10.0.0.2	255.0.0.0	02:30:CD:00:06:18

Number of ethernet devices connected to the DHCP server: 1

	IP Address	MAC Address
1	10.0.0.3	00:30:CD:00:06:18

Status

[Home](#)
[ADSL](#)
[LAN](#)
[PPP](#)

Configuration

[WAN](#)
[LAN](#)
[DNS](#)
[Save Settings](#)

Admin Privilege

[WAN Status](#)
[ATM Status](#)
[TCP Status](#)
[ADSL Configuration](#)
[Password Configuration](#)
[Admin User](#)
[Misc Configuration](#)
[Reset to Factory Default](#)
[Diagnostic Test](#)
[System Log](#)

To view information about your Prestige, click the links under **Status**. Click **Home** to return to the **Home Page** at any time.

To configure the Prestige, click the links under **Configuration**.

If you logged in as an administrator, you will have access to the links under **Admin Privilege**, where you can do tasks such as modifying the ADSL configuration, performing system tests, and resetting modem defaults.

Figure 4-5 Home Page

Chapter 5

Status Information

This chapter describes how to view the Prestige's status information.

5.1 Prestige Status Information Overview

The web configurator allows you to view important status information about your Prestige by clicking the links under **Status** in the navigation panel.

5.2 ADSL Status Information

Click **ADSL** to view the **ADSL STATUS** screen as shown next.

ADSL STATUS			
ADSL Line State:	ACTIVATION		
ADSL Modulation:	N/A		
ADSL Annex Mode:	ANNEX_A		
ADSL Startup Attempts:	0		
Elapsed Time:	0 days 0 hours 11 minutes 21 seconds		
	Downstream	Upstream	
SNR Margin	NA	NA	dB
Line Attenuation	NA	NA	dB
Errored Seconds	0	0	
Loss of Signal	0	0	
Loss of Frame	0	0	
CRC Errors	0	0	
Data Rate	0	0	kbps
Latency	NA	NA	

Figure 5-1 ADSL Status

The following table describes the fields in this screen.

Table 5-1 ADSL Status

LABEL	DESCRIPTION
ADSL Line State	This is the current state of the ADSL line.
ADSL Modulation	This field displays the ADSL modulation status for G.dmt or T1.413.
ADSL Annex Mode	This displays the annex mode (Annex A or Annex B).
ADSL Startup Attempts	This displays the number of ADSL connection attempts.
Elapsed Time	This is the time the modem has been in operation.

Table 5-1 ADSL Status

LABEL	DESCRIPTION
The following fields display upstream and downstream statistics for the ADSL connection.	
SNR Margin	This is the amount of increased noise that can be tolerated while maintaining the designed BER (bit error rate). The SNR Margin is set by the Central Office DSLAM. If the SNR Margin is increased, bit error rate performance will improve, but the data rate will decrease. Conversely, if the SNR Margin is decreased, bit error rate performance will decrease, but the data rate will increase.
Line Attenuation	Attenuation is the decrease in magnitude of the ADSL line signal between the transmitter (Central Office DSLAM) and the receiver (the Prestige), measured in dB. It is measured by calculating the difference in dB between the signal power level received at the Prestige and the reference signal power level transmitted from the Central Office DSLAM.
Errored Seconds	This is the number of errors. Whenever a given second contains a CRC error, that second will be declared an error second.
Loss of Signal	This field displays the number of times the ADSL signal has been lost.
Loss of Frame	This field displays the number of times an ADSL frame has been lost.
CRC Errors	This is the total number of frames that have CRC errors.
Data Rate	This is the ADSL data rate.
Latency	This field displays the latency modes (fast or interleave).

5.3 Viewing LAN Status

Click **LAN** to view the **LAN** screen as shown next.

LAN		
IP Address	Subnet Mask	MAC Address
10.0.0.2	255.0.0.0	02:30:CD:00:06:18
Number of ethernet devices connected to the DHCP server: 1		
	IP Address	MAC Address
1	10.0.0.3	00:30:CD:00:06:18
USB Link Status: UP		

The following table describes the fields in this screen.

Table 5-2 LAN Status

LABEL	DESCRIPTION
IP Address	This is the IP address of your Prestige in dotted decimal notation.
Subnet Mask	This is corresponding subnet mask for the above IP Address.
MAC Address	This is the MAC address of your Prestige.
Number of Ethernet devices connected to the DHCP server:	This shows the number of devices that the Prestige's DHCP server can recognize.
IP Address	This is the IP address of your computer in dotted decimal notation.
MAC Address	This is corresponding subnet mask for the above IP Address.
USB Link Status	This shows the status of the USB link (UP or DOWN).

5.4 Viewing PPP Interface Status

Click **PPP** to view the **PPP** screen as shown next.

PPP

#	Connection Name	Interface	Mode	Status	Pkts Sent	Pkts Rcvd	Bytes Sent	Bytes Rcvd
1	simple ppp session 0	Pvc 0	PPPoE	Not Connected	N/A	N/A	N/A	N/A

If a * appears under Mode column, you need to [check the WAN configuration](#) to make sure the VC has the correct encapsulation.

Connection #

Figure 5-2 PPP Status

The following table describes the fields in this screen.

Table 5-3 PPP Status

LABEL	DESCRIPTION
#	This is the identification number of the PPP connection.
Connection Name	This is an identifier given to the connection.
Interface	This is type of PPP interface.
Mode	This is the PPP mode (PPPoE or PPPoA).
Status	This is the current status of the PPP connection (Connected or Not Connected).
Pkts Sent	This is the total number of packets sent.
Pkts Rcvd	This is the total number of packets received.
Bytes Sent	This is the total number of bytes sent.
Bytes Rcvd	This is the total number of bytes received.
check the WAN configuration	Click this link to go to the WAN screen (see <i>Figure 6-1 WAN Configuration</i>) to edit the encapsulation.
Connection #	Select a connection number to view its connection status.

Table 5-3 PPP Status

LABEL	DESCRIPTION
Connect/Disconnect	Choose Connect or Disconnect from the drop-down list box to change the change the status of the PPP connection.
Execute	Click the Execute button to connect or disconnect the PPP connection.

Chapter 6

Basic Configuration

This chapter describes how to configure your Prestige's basic settings.

6.1 Configuration Overview

You can configure your Prestige for Internet access through the links under **Configuration** in the navigation panel.

6.2 Configuring WAN

Click **WAN** to configure your Prestige's WAN settings. See *Table 6-2 WAN Configuration Options* for a list of options available.

WAN Configuration

VPI	VCI	Static IP Address	Subnet Mask	Gateway
0	35	192.168.241.101	255.255.255.0	0.0.0.0

ATM

Service Category UBR ▾

Bandwidth 0 kbps

ENCAPSULATION PPPoE LLC ▾

PPP

Service Name

Username

Password

MRU

MTU

MSS

Disconnect Timeout 0 seconds (Max: 32767)

Authentication Auto ▾

Automatic Reconnect

DHCP

DHCP client enable

Host Name

Settings need to be saved to Flash and the system needs to be rebooted for changes to take effect.

Figure 6-1 WAN Configuration

The following table describes the fields in this screen.

Table 6-1 WAN Configuration

LABEL	DESCRIPTION
VPI	Enter the Virtual Path Identifier(s) (VPI) given.
VCI	Enter the Virtual Channel Identifier(s) (VCI) given.
Static IP Address	This is the static IP provided by your ISP.
Subnet Mask	This is the corresponding subnet mask for the above IP address.
Gateway	This is the gateway IP address.
ATM	
Service Category	Select the service category (UBR or CBR).
Bandwidth	Bandwidth setting takes effect only when the CBR is selected. Enter a bandwidth in kbps.
Encapsulation	Choose an encapsulation type. The choices are as follows: PPPoA VC-MUX, PPPoA LLC, 1483 Bridged IP LLC, 1483 Routed IP LLC, 1483 Bridged IP VC-Mux, 1483 Routed IP VC-Mux, Classical IP over ATM, PPPoE VC-Mux, PPPoE LLC, and PPPoE None.
PPP	
Service Name	If your ISP provided you a service name, enter it here.
User Name	Enter your ISP-assigned user name.
Password	Enter your ISP-assigned password.
MRU	The Maximum Receive Unit (MRU) indicates the maximum size of the PPP information field that this device can receive. The default value is 1492 and is used in the beginning of the PPP negotiation. During negotiation, the peer will accept this MRU and will not send packets with information fields larger than this value.
MTU	If the network stack of any packet is larger than the Maximum Transmission Unit (MTU), it will be fragmented before transmission. During PPP negotiation, the peer of the PPP connection will indicate its MRU. The actual MTU of the PPP connection will be set to either the MTU or the peer's MRU (whichever is smaller). The default is value 1492.
MSS	The Maximum Segment Size (MSS) is the largest size of data that TCP will send in a single IP packet. When a connection is established between a LAN client and a host on the WAN side, the LAN client and the WAN host will indicate their MSS during the TCP connection handshake. The default value is 1432.

Table 6-1 WAN Configuration

LABEL	DESCRIPTION
Disconnect Timeout	Enter a time in seconds after which the PPP connection will disconnect if the line is idle (max: 32767 seconds).
Authentication	This field sets the authentication protocol used for outgoing calls. Options for this field are: Auto – Your Prestige will accept either CHAP or PAP when requested by this remote node. PAP mode will run first, and then CHAP. CHAP – accept CHAP only. PAP – accept PAP only.
Automatic Reconnect	Select this check box to maintain PPP connection. If the ISP shuts down the PPP connection, it will automatically reconnect PPP session.
DHCP	
DHCP Client Enable	Select Enabled or Disabled to change the status of the DHCP client.
Host Name	If your ISP provided a host name, enter it here.
Submit	Click this button to submit the changes.
Reset	Click this button to reset all values to their defaults.

Table 6-2 WAN Configuration Options

LABEL	Bridge Mode	Router Mode (PPPoA/PPPoE)	Router Mode (Dynamic IP)	Router Mode (Static IP)
IP address	N/A	Automatically assigned by ISP	Automatically assigned by ISP	Provided by ISP
Subnet Mask	N/A	Automatically assigned by ISP	Automatically assigned by ISP	Provided by ISP

Table 6-2 WAN Configuration Options

LABEL	Bridge Mode	Router Mode (PPPoA/PPPoE)	Router Mode (Dynamic IP)	Router Mode (Static IP)
Encapsulation	1483 Bridged IP LLC 1483 Bridged IP VC-Mux	PPPoA, LLC/VC-Mux PPPoE, LLC/VC-Mux	1483 Bridged/Routed IP LLC 1483 Bridged/Routed IP VC-Mux Classical IP over ATM	1483 Bridged/Routed IP LLC 1483 Bridged/Routed IP VC-Mux Classical IP over ATM
Bridge	Enabled	Disabled	Disabled	Disabled
PPP Service	N/A	Provided by ISP	N/A	N/A
PPP User Name	N/A	Provided by ISP	N/A	N/A
PPP Password	N/A	Provided by ISP	N/A	N/A
DHCP Client Enable	Unchecked	Unchecked	Checked	Unchecked

6.3 Configuring LAN

Click **LAN** to configure your Prestige's LAN settings.

LAN Configuration

IP Address

Subnet Mask

DHCP Server

DHCP address pool selection System Allocated
 User Defined

User Defined Start Address

User Defined End Address

Lease Time days hours minutes seconds

Settings need to be saved to Flash and the system needs to be rebooted for the changes to take effect.

Figure 6-2 LAN Configuration

The following table describes the fields in this screen.

Table 6-3 LAN Configuration

LABEL	DESCRIPTION
IP Address	Enter the LAN IP address of the modem in dotted decimal notation. <div style="border: 1px solid gray; background-color: #e0e0e0; padding: 5px; text-align: center; font-weight: bold;"> The default IP address is 10.0.0.2. If you change the LAN IP address, you must to use the new IP address to access the web configurator. </div>
Subnet Mask	This is the subnet mask corresponding to the IP address above. The default subnet mask is 2555.0.0.0.
DHCP Server	Select this checkbox to enable the DHCP server.

Table 6-3 LAN Configuration

LABEL	DESCRIPTION
DHCP address pool selection	<p>This sets the DHCP address pool.</p> <p>If System Allocated is selected, the DHCP address pool range starts at the LAN port IP address and includes the next 12 IP addresses. For example, if the LAN IP address is 10.0.0.2; the DHCP address pool range is 10.0.0.3 to 10.0.0.14.</p> <p>If User Defined is selected, the DHCP address pool range includes all IP addresses from the User Defined Start Address to the User Defined End Address. The maximum pool size can be 253 IP addresses: 255 total IP addresses in total, including 1 broadcast address and 1 LAN port IP address.</p>
User Defined Start Address/User Defined End Address	<p>If you selected User Defined in the DHCP address pool selection field above, you must enter a start and end IP address. The IP addresses in this range will be available to be assigned to hosts connected to your Prestige.</p>
Lease Time	<p>The lease time is the amount of time a network user will be allowed to connect with the DHCP server. Enter the number of days, hours, minutes and/or seconds. If all fields are 0, the allocated IP addresses will be effective indefinitely.</p>
Submit	<p>Click this button to apply the changes.</p>
Reset	<p>Click this button to reset all values to their defaults.</p>

6.4 Configuring DNS

Click **DNS** to configure your Prestige's DNS settings.

DNS Configuration

DNS Proxy Selection

User Configuration:

Preferred DNS Server

Alternate DNS Server

Settings need to be saved to Flash and the system needs to be rebooted for the changes to take effect.

Figure 6-3 DNS Configuration

The following table describes the fields in this screen.

Table 6-4 DNS Configuration

LABEL	DESCRIPTION
DNS Proxy Selection	<p>Select a DNS proxy selection from the options below:</p> <p>Disable DNS Proxy: If the DNS proxy is disabled, the LAN port does not process DNS query messages. For the DHCP requests from local machines, the DHCP server will select either the server configured in the Preferred DNS Server field or the server configured in the Alternate DNS Server field (see below).</p> <p>Use Auto Discovered DNS Servers Only: If this selection is made, the DNS proxy will store the DNS server IP addresses obtained from PPP and all DNS query messages will be sent to one of these dynamically obtained DNS server information.</p> <p>Use User Configured DNS Servers Only: The DHCP server will select either the server configured in the Preferred DNS Server field or the server configured in the Alternate DNS Server field (see below).</p> <p>Auto Discovery + User Configured: The DNS proxy's table will store all the IP addresses of dynamically obtained and user configured DNS servers.</p>
User Configuration	
Preferred DNS Server	Enter the IP address in dotted decimal notation of a preferred DNS server.
Alternate DNS Server	Enter the IP address in dotted decimal notation of a backup or alternate DNS server.
Submit	Click this button to apply the changes.
Reset	Click this button to reset all values to their defaults.

6.5 Saving New Settings

You may click the **Save Settings** link in the navigation panel at any time to save you settings and allow your Prestige to reboot. Click the **Submit** button as shown.

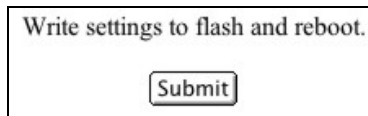

Figure 6-4 Save Settings

Chapter 7

Administrative Privileges

This chapter describes how to configure your Prestige with the administrator-level access.

7.1 Administration Privileges Overview

If you logged in as an administrator, perform advanced configuration through the links under **Admin Privilege** in the navigation panel.

7.2 WAN Status

Click **WAN Status** to view WAN-related information and status of the WAN connection. This is the same information that appears on the **Home Page**.

WAN		
IP Address	Subnet Mask	MAC Address
0.0.0.0	255.0.0.0	00:30:CD:00:06:19
<input type="button" value="Release"/> <input type="button" value="Execute"/>		

Figure 7-1 WAN Status

The following table describes the fields in this screen.

Table 7-1 WAN Status

LABEL	DESCRIPTION
IP Address	This is the IP Address for the WAN interface.
Subnet Mask	This is the subnet mask for the above IP address.
MAC Address	This is the MAC Address for the WAN interface.
Release/Renew	Select Release or Renew to change the status of the WAN IP address when the WAN DHCP Client is enabled (dynamic mode).

Table 7-1 WAN Status

LABEL	DESCRIPTION
Execute	Click this button to release or renew the WAN IP address.

7.3 ATM Status

Click **ATM Status** to view ATM cell statistics.

ATM STATUS	
Tx Bytes	0
Rx Bytes	0
Tx Cells	0
Rx Cells	0
Rx HEC Errors	0
Tx Mgmt Cells	0
Rx Mgmt Cells	0
Tx CLP0 Cells	0
Rx CLP0 Cells	0
Tx CLP1 Cells	0
Rx CLP1 Cells	0
Rx Errors	0
Tx Errors	0
Rx Misrouted Cells	0

The following table describes the fields in this screen.

Table 7-2 ATM Status

LABEL	DESCRIPTION
Tx Bytes	This is the total number of bytes transmitted.
Rx Bytes	This is the total number of bytes received.
Tx Cells	This is the total number of cells transmitted.
Rx Cells	This is the total number of cells received.
Rx HEC Errors	This is the total number of Header Error Control (HEC) errors received.
Tx Mgmt Cells	This is the total number of management cells transmitted.
Rx Mgmt Cells	This is the total number of management cells received.
Tx CLP0 Cells	This refers to the number of cells transmitted with the CLP bit in the header set to zero.
Rx CLP0 Cells	This refers to the number of cells received with the CLP bit in the header set to zero.
Tx CLP1 Cells	This refers to the number of cells transmitted with the CLP bit in the header set to one.
Rx CLP1 Cells	This refers to the number of cells received with the CLP bit in the header set to one.
Rx Errors	This is the total number of cells received containing errors.
Tx Errors	This is the total number of cells transmitted containing errors.
Rx Misrouted Cells	This is the number of misrouted cells received.

Figure 7-2 ATM Status

7.4 TCP Status

Click **TCP Status** to view TCP connection-related information.

Total Packets Sent	1288
Data Packets Sent	584
Data Bytes Sent	353219
Total Packets Received	1234
Packets Received in-sequence	233
Bytes Received in-sequence	70581
Out of Order Packets	232
Out of Order Bytes	0
Packets disgarded for bad checksum	0
Packets disgarded for bad header offset	0
Packets disgarded because too short	0
Connections Initiated	6
Connections Accepted	233
Connections Established	233
Connections Closed	225

Figure 7-3 TCP Status

The following table describes the fields in this screen.

Table 7-3 TCP Status

LABEL	DESCRIPTION
Total Packets Sent	This is the total number of packets sent.
Data Packets Sent	This is the total number of data packets sent.
Data Bytes Sent	This is the total number of data bytes of data sent.
Total Packets Received	This is the total number of packets received.
Packets Received in Sequence	This is the total number of packets that were received in sequence.
Bytes Received in Sequence	This is the total number of bytes that were received in sequence.
Out of Order Packets	This is the total number of packets that were sent and received out of order.
Out of Order Bytes	This is the total number of bytes that were sent and received out of order.
Packets discarded for bad checksum	This is the total number of packets discarded because of having a bad checksum.
Packets discarded for bad header offset	This is the total number of packets discarded because of having a bad header offset.
Packets discarded because too short	This is the total number of packets discarded because they were too short.
Connections Initiated	This is the number of TCP connections initiated.
Connections Accepted	This is the number of TCP connections accepted.
Connections Established	This is the number of TCP connections established.
Connections Closed	This is the number of TCP connections closed.

7.5 ADSL Configuration

Click **ADSL Configuration** to configure advanced ADSL settings.

ADSL Configuration

<input type="button" value="Enabled"/>	Trellis
<input type="button" value="G.lite"/>	Handshake Protocol
<input type="button" value="Tip/Ring"/>	Wiring Selection
<input type="button" value="Enabled"/>	Bit Swapping (No system reboot needed)

Settings need to be saved to Flash and the system needs to be rebooted for changes to take effect.

Figure 7-4 ADSL Configuration

The following table describes the fields in this screen.

Table 7-4 ADSL Configuration

LABEL	DESCRIPTION
Trellis	Select Enabled or Disabled to activate or deactivate the Trellis code. It is enabled by default.
Handshake Protocol	Select an ADSL handshake protocol. The choices are as follows: Autosense-G.dmt first , Autosense-T1.413 first , G.dmt/G.lite , T1.413 , G.dmt , G.lite .
Wiring Selection	Make a wiring selection for the RJ-11 port. Tip/Ring is the default for the board without the inner/outer pair relay. The other choices are A/A1 and Auto .
Bit Swapping (No system reboot needed)	Select Enabled or Disabled to activate or deactivate upstream bit swapping.
Submit	Click this button to submit the changes.
Reset	Click this button to reset all values to their defaults.

7.6 Admin Password Configuration

Click **Admin** under **Password Configuration** to change your Prestige’s web configurator administrator password.

Admin Password Configuration

For FTP to work, the password for Admin should be at least 8 characters. Do not use '&' in the password.

Admin Password

Retype Password

Settings need to be saved to Flash and the system needs to be rebooted for changes to take effect.

Figure 7-5 Admin Password Configuration

The following table describes the fields in this screen.

Table 7-5 Admin Password Configuration

LABEL	DESCRIPTION
Admin Password	Enter a new password for administrator login. The password may be up to 65 characters long and may not include an ampersand "&". For FTP to work, the password needs to be at least 8 characters.
Retype Password	Retype the password to confirm.
Submit	Click this button to submit the changes.
Reset	Click this button to reset all values to their defaults.

7.7 User Password Configuration

Click **User** under **Password Configuration** to change your Prestige's web configurator user password.

User Password Configuration

Do not use '&' in the password.

User Password

Retype Password

Settings need to be saved to Flash and the system needs to be rebooted for changes to take effect.

Figure 7-6 User Password Configuration

The following table describes the fields in this screen.

Table 7-6 User Password Configuration

LABEL	DESCRIPTION
User Password	Enter a new password for user login. The password may be up to 65 characters long and may not include an ampersand “&”.
Retype Password	Retype the password.
Submit	Click this button to submit the changes.
Reset	Click this button to reset all values to their defaults.

7.8 Miscellaneous Configuration

Click **Misc Configuration** to configure additional HTTP and PPP settings.

Miscellaneous Configuration

HTTP server access

All

Restricted

LAN

WAN Specify IP

Subnet Mask

HTTP server port

PPP disconnect on LAN probe timeout ▾

PPP reconnect on Internet access ▾

Settings need to be saved to Flash and the system needs to be rebooted for changes to take effect.

Figure 7-7 Miscellaneous Configuration

The following table describes the fields in this screen.

Table 7-7 Miscellaneous Configuration

LABEL	DESCRIPTION
HTTP server access	In this section, you can configure how from where the web configurator can be accessed.
All	Select All to allow access from both the LAN and WAN.
Restricted LAN	Select the Restricted radio button and the LAN check box to restrict access to the Prestige from a computer on the LAN.
Restricted WAN	Select the Restricted radio button and the WAN check box to restrict access to the Prestige from a computer on the WAN with a specific IP address.
Specify IP	Enter the IP address of the computer on the WAN that is allowed to access the Web Configurator.
Subnet Mask	Enter the corresponding subnet mask for the above IP address.
HTTP server port	This field allows you to specify a port for the Web server. For example, when set to 1001, the HTTP server address for the LAN side is http://10.0.0.2:1001, where 10.0.0.2 is the default IP Address).
PPP disconnect on LAN probe timeout	Select Enabled to allow the PPP session to timeout (see <i>section 6-1</i>). Select Disabled to prevent disconnection due to timeout.
PPP reconnect on WAN access	Select Enabled to have a PPP session automatically reconnect when a packet is sent to the WAN. Select Disabled to prevent reconnection.
Submit	Click this button to apply the changes.
Reset	Click this button to reset all values to their defaults.

7.9 Restoring Factory Defaults

To restore the factory defaults on your Prestige, click **Reset to Factory Defaults**; the following screen will appear. Click **Submit** to confirm.

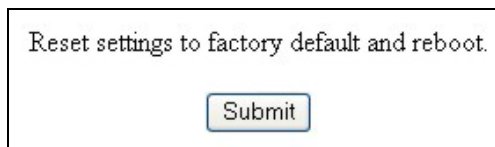
**Figure 7-8 Restore Factory Defaults**

7.10 Performing a Diagnostic Test

Your Prestige can perform a diagnostic test on the physical and protocol layers for both the LAN and WAN sides. Click **Diagnostic Test** to perform the test and view the results. Click a **Help** link to view a description of each test.

```

Diagnostic Test

Checking USB Connection
  Testing USB connection                : PASS   HELP

Checking ADSL Connection
  Testing ADSL Synchronization         : FAIL   HELP

Checking Circuit 0 for Network Connection
  Test ATM OAM Segment Loop Back      : SKIPPED HELP
  Test ATM OAM End-to-End Loop Back   : SKIPPED HELP
  Test Ethernet connect to ATM        : SKIPPED HELP
  Test simple ppp session 0 PPPOE connection : SKIPPED HELP
  Test simple ppp session 0 PPP Layer connection : SKIPPED HELP
  Test simple ppp session 0 IP connect to PPP : SKIPPED HELP

Testing Internet Connection
  Ping primary DNS                     : SKIPPED HELP
  Query DNS for www.ZyXEL.com          : SKIPPED HELP
  Ping www.ZyXEL.com                   : SKIPPED HELP
    
```

Figure 7-9 Diagnostic Test

The following table describes the fields in this screen.

Table 7-8 Diagnostic Test

LABEL	DESCRIPTION
Checking USB Connection	
Testing USB Connection	This test checks if the USB connection or port is working properly.
Checking ADSL Connection	
Testing ADSL Synchronization	This test checks your Prestige to see if it can successfully negotiate and establish an ADSL connection with your ISP.
Checking Circuit x for Network Connection	

Table 7-8 Diagnostic Test

LABEL	DESCRIPTION
Test ATM OAM Segment Loop Back	This test sends ATM OAM F5 Segment loop back request cells to the central office equipments through your DSL connection. This test returns PASS if response cell is received. Since your service provider might not support this test, your Prestige can still work even if this test fails.
Test ATM OAM End-to-End Loop Back	This test sends ATM OAM End-to-End loop back request cells to the central office equipments through your DSL connection. This test returns PASS if response cell is received. Since your service provider might not support this test, your Prestige can still work even if this test fails.
Test Ethernet connect to ATM	This test checks the Ethernet/ATM connection.
Test PPPoPvc 0 PPPOE connection	This test returns PASS if your Prestige can connect to a PPPoE server.
Test PPPoPvc 0 PPP layer connection	This test returns PASS if your login name and password have passed authentication with your service provider. This test returns SKIPPED if the PPPoE connection test does not return PASS and your Prestige is configured with PPPoE encapsulation.
Test PPPoPvc 0 IP connect to PPP	This test returns PASS if your Prestige has been assigned a valid IP address by your service provider through DHCP or your DSL modem is assigned a valid IP address statically.
Testing Internet Connection	
Ping Primary DNS	This test returns PASS if the primary DNS can be reached through a ping request. The primary DNS is assigned by your service provider or obtained from your service provider by PPP or DHCP negotiation.
Query DNS for	This test returns PASS if the host name can be resolved to an IP address though the domain name servers.
Ping	This test returns PASS if the host specified by your ISP can be reached through a ping request.

7.11 System Log

Click **System Log** to view the Prestige's log file. Entries are added to the log file when events are triggered by the system.

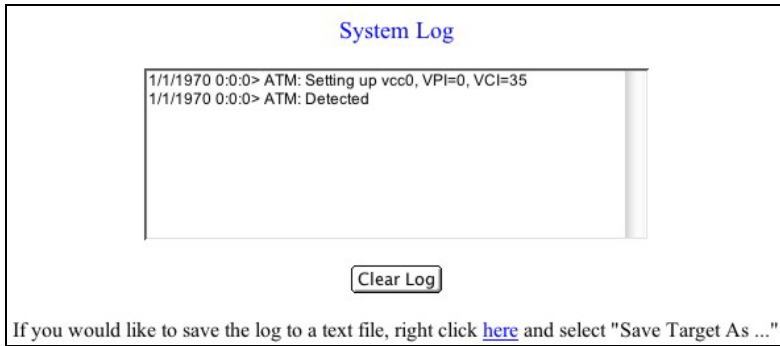

Figure 7-10 System Log

The following table describes the information in this screen.

Table 7-9 System Log

LABEL	DESCRIPTION
Date and Time	The log records the date and time of an event.
Clear Log	Click this button to clear the log.
here (save log link)	Left click this link to view the log in html form. Right click this link and select "Save Target As..." to save the log as a text file.

7.12 Making a DSL Connection with PPPoE

Use the following steps to configure your Macintosh when using PPPoE. PPPoE is a dial-up connection, so you configure the driver and create a dial-up connection to use.

- Step 1.** Click the Apple icon and **System Preferences** and then **Networking** (see *Figure 4-1* and *Figure 4-2*).
- Step 2.** A **New Port Detected** screen opens when the computer detects that the ADSL link is up. Click **OK** (see *Figure 4-3*).
- Step 3.** In the **Network** screen, select **Ethernet Adaptor (en x)** in the **Show** field. Click the **PPPoE** tab and select the **Connect using PPPoE** check box. Type the information from your ISP in the **PPPoE Service Name**, **Account Name** and **Password** fields. Select the **Show PPPoE status in menu bar** check box. Click **Apply Now**.



Figure 7-11 Network: PPPoE Tab

Step 4. Click the menu bar icon and select **Connect**.



Figure 7-12 PPPoE Icon Connect

7.13 Uninstalling the Hardware and Driver

Disconnect the USB cable from your Macintosh's USB port.

Use the following steps to remove your modem's software driver.

It is recommended that you save and close all other running programs before uninstalling the modem driver.

- Step 1.** Open the drive you selected during installation (see section 3.3).
- Step 2.** Double-click the **Uninstall** icon.
- Step 3.** If your computer prompts you to confirm the selection, click **Yes**. You may need to enter a password if the administrator who installed the Prestige requires one.
- Step 4.** Restart your computer when prompted to do so.

Chapter 8

Troubleshooting

This chapter covers potential problems and the possible solutions.

Table 8-1 Troubleshooting

PROBLEM	CORRECTIVE ACTION
None of the LEDs turn on when I start the modem.	<p>Make sure your computer is turned on.</p> <p>Check the USB cable connections between the modem and your computer.</p> <p>Carefully follow the instructions in this <i>User's Guide</i> to uninstall and reinstall the software driver.</p>
I cannot access the Prestige on my computer.	<p>Make sure the modem's USB port is connected to your computer's USB port.</p> <p>Restart your computer.</p>
I cannot connect to the Internet.	<p>Make sure the ADSL port is properly connected to the telephone wall jack.</p> <p>Select Connect/Disconnect from the menu at the top of your computer screen.</p> <p>Make sure that you have configured the correct user name and password on the WAN settings (see <i>section 6-1 WAN Settings</i>).</p> <p>Restart your computer.</p>

Appendix A

Setting up Your Computer's IP Address

Follow the steps to set up your USB computer to use a static IP address given by your ISP. Steps and screen shots may vary depending on the version of Macintosh.

Macintosh OS 9

1. Click the **Apple** menu, **Control Panel** and double-click **TCP/IP** to open the **TCP/IP Control Panel**.

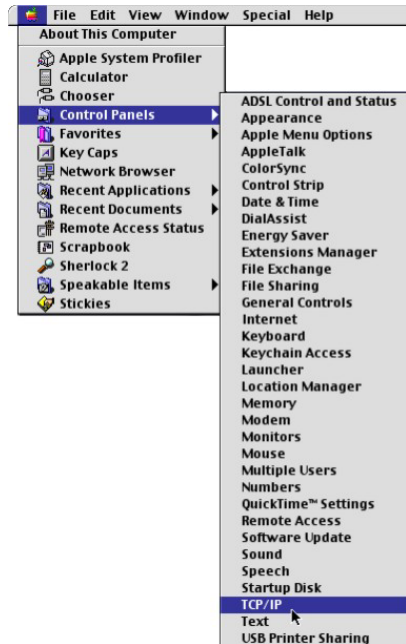

2. Select **Ethernet built-in** from the **Connect via** list.

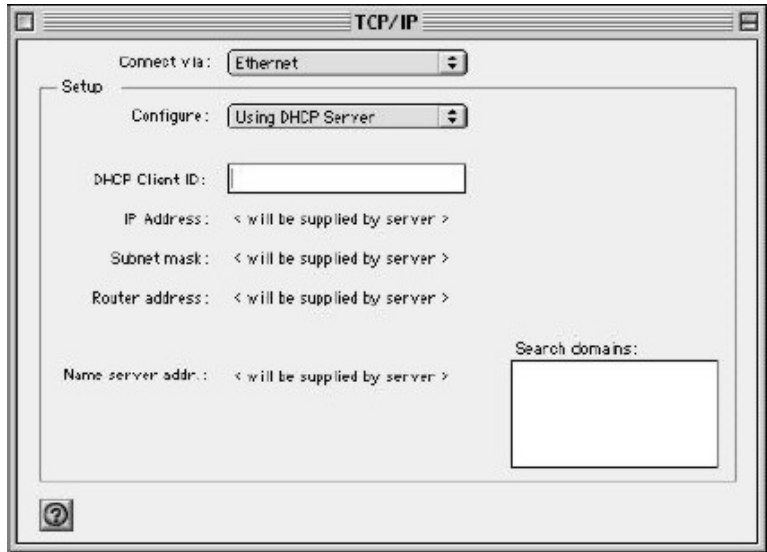

3. For dynamically assigned settings, select **Using DHCP Server** from the **Configure:** list.
4. For statically assigned settings, do the following:
 - From the **Configure** box, select **Manually**.
 - Type your IP address in the **IP Address** box.
 - Type your subnet mask in the **Subnet mask** box.
 - Type the IP address of your Prestige in the **Router address** box.
5. Close the **TCP/IP Control Panel**.
6. Click **Save** if prompted, to save changes to your configuration.
7. Turn on your Prestige and restart your computer (if prompted).

Check your TCP/IP properties in the **TCP/IP Control Panel** window.

Macintosh OS X

1. Click the **Apple** menu, and click **System Preferences** to open the **System Preferences** window.

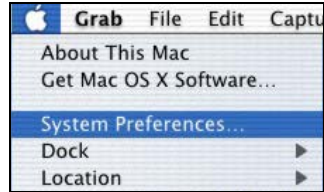

2. Click **Network** in the icon bar.
 - Select **Automatic** from the **Location** list.
 - Select **Built-in Ethernet** from the **Show** list.
 - Click the **TCP/IP** tab.

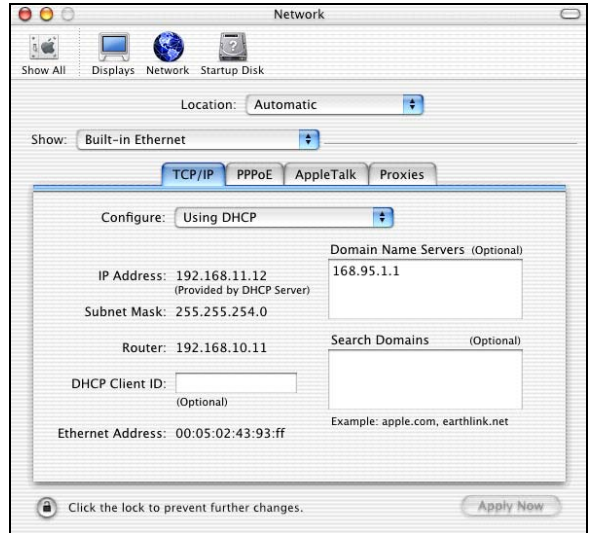

3. For dynamically assigned settings, select **Using DHCP** from the **Configure** list.
4. For statically assigned settings, do the following:
 - From the **Configure** box, select **Manually**.
 - Type your IP address in the **IP Address** box.
 - Type your subnet mask in the **Subnet mask** box.
 - Type the IP address of your Prestige in the **Router address** box.
5. Click **Apply Now** and close the window.
6. Turn on your Prestige and restart your computer (if prompted).

Check your TCP/IP properties in the **Network** window.

Appendix B

Virtual Circuit Topology

ATM is a connection-oriented technology, meaning that it sets up virtual circuits over which end systems communicate. The terminology for virtual circuits is as follows:

- **Virtual Channel** Logical connections between ATM switches
- **Virtual Path** A bundle of virtual channels
- **Virtual Circuit** A series of virtual paths between circuit end points

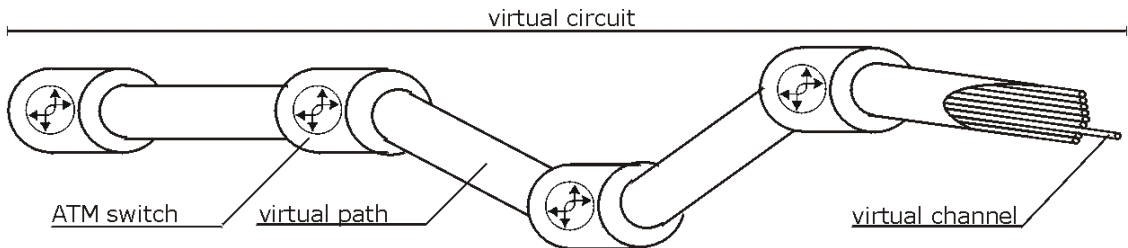

Diagram 1 Virtual Circuit Topology

Think of a virtual path as a cable that contains a bundle of wires. The cable connects two points and wires within the cable provide individual circuits between the two points. In an ATM cell header, a VPI (Virtual Path Identifier) identifies a link formed by a virtual path; a VCI (Virtual Channel Identifier) identifies a channel within a virtual path.

The VPI and VCI identify a virtual path, that is, termination points between ATM switches. A series of virtual paths make up a virtual circuit.

Your service provider should supply you with VPI/VCI numbers.

Index

	A			O	
About ADSL		xiii	Online Registration		iii
ADSL		xiii	Operating Systems		3-1
Advantages of ADSL		xiii		P	
Advantages of USB		xv	Packing List Card		xi
Always on		xiii	PAP		6-4
Asymmetric Operation		xiii	Power Supply		1-1
Authentication		6-4	Private		xiii
	C			R	
CHAP		6-4	Read Me First		xi
Compatibility and Compliance		1-1, xi, 1-1	Related Documentation		xi
Computer's IP Address		A	Repair		iii
Configuration		4-1	RFC 1483		3-2
Connections		2-2	RFC1483		4-1
Contacting Customer Support		vi	RJ-11		1-1
Copyright		ii		S	
Disclaimer		ii	Secure Channel		xiii
Trademarks		ii	Service		iii
Customer Support		vi	Support Disk		xi
	D		Syntax Conventions		xii
Downstream Data Rates		1-1		T	
	F		Telephone Service, Coexistence with DSL		xiii
FCC		v	Troubleshooting		8-1
FCC Rules		v		U	
Features		1-1	Upstream Data Rates		1-1
Federal Communications Commission (FCC)			USB		xv
Interference Statement		v	USB as Power Source		1-1
	I		USB Compliance		1-1
Information for Canadian Users		iv	USB, advantages		xv
Caution		iv	USB, What is it?		xv
Note		iv		W	
	L		Warranty		iii
LEDs		2-1		Z	
Limited Warranty		iii	ZyXEL Contact Information		vi
	M		ZyXEL Limited Warranty		
Macintosh Configuration		4-1	Note		iii
Microfilter		2-2	ZyXEL Web Site		xi
	N				
Needed Information		3-1			